

EVLYS LTD. - POWER SEMICONDUCTORS DEVICES - Wholesale and Retail.

Fast Thyristor Type **FDT56-1000-22**

Low switching losses / Low reverse recovery charge
Distributed amplified gate for high di_T/dt

Mean on-state current	I_{TAV}	1000 A	
Repetitive peak off-state voltage	V_{DRM}	1800...2200 V	
Repetitive peak reverse voltage	V_{RRM}		
Turn-off time	t_q	20.0, 25.0, 32.0, 40.0 μs	
V_{DRM}, V_{RRM}, V	1800	2000	2200
Voltage code	18	20	22
$T_{j,r}, ^\circ C$	-60...+125		

MAXIMUM ALLOWABLE RATINGS

Symbols and parameters		Units	Values	Test conditions
ON-STATE				
I_{TAV}	Mean on-state current	A	909 1000 1363	$T_c = 85^\circ C$; Double side cooled; $T_c = 79^\circ C$; Double side cooled; $T_c = 55^\circ C$; Double side cooled; 180° half-sine wave; 50 Hz
I_{TRMS}	RMS on-state current	A	1570	$T_c = 79^\circ C$; Double side cooled; 180° half-sine wave; 50 Hz
I_{TSM}	Surge on-state current	kA	22.0 25.0	$T_j = T_{j,max}$ $T_j = 25^\circ C$ 180° half-sine wave; $t_p = 10$ ms; single pulse; $V_D = V_R = 0$ V; Gate pulse: $I_G = I_{FGM}$; $V_G = 20$ V; $t_{GP} = 50$ μs ; $di_G/dt = 1$ A/ μs
			23.0 26.0	$T_j = T_{j,max}$ $T_j = 25^\circ C$ 180° half-sine wave; $t_p = 8.3$ ms; single pulse; $V_D = V_R = 0$ V; Gate pulse: $I_G = I_{FGM}$; $V_G = 20$ V; $t_{GP} = 50$ μs ; $di_G/dt = 1$ A/ μs
I^2t	Safety factor	$A^2s \cdot 10^3$	2400 3100	$T_j = T_{j,max}$ $T_j = 25^\circ C$ 180° half-sine wave; $t_p = 10$ ms; single pulse; $V_D = V_R = 0$ V; Gate pulse: $I_G = I_{FGM}$; $V_G = 20$ V; $t_{GP} = 50$ μs ; $di_G/dt = 1$ A/ μs
			2100 2800	$T_j = T_{j,max}$ $T_j = 25^\circ C$ 180° half-sine wave; $t_p = 8.3$ ms; single pulse; $V_D = V_R = 0$ V; Gate pulse: $I_G = I_{FGM}$; $V_G = 20$ V; $t_{GP} = 50$ μs ; $di_G/dt = 1$ A/ μs
BLOCKING				
V_{DRM}, V_{RRM}	Repetitive peak off-state and Repetitive peak reverse voltages	V	1800...2200	$T_{j,min} < T_j < T_{j,max}$; 180° half-sine wave; 50 Hz; Gate open
V_{DSM}, V_{RSM}	Non-repetitive peak off-state and Non-repetitive peak reverse voltages	V	1900...2300	$T_{j,min} < T_j < T_{j,max}$; 180° half-sine wave; single pulse; Gate open
$V_{D,r}, V_{R}$	Direct off-state and Direct reverse voltages	V	$0.6 \cdot V_{DRM}$ $0.6 \cdot V_{RRM}$	$T_j = T_{j,max}$; Gate open

EVLYS LTD. - POWER SEMICONDUCTORS DEVICES - Wholesale and Retail.

TRIGGERING				
I_{FGM}	Peak forward gate current	A	8	$T_j = T_{j\max}$
V_{RGM}	Peak reverse gate voltage	V	5	
P_G	Gate power dissipation	W	8	$T_j = T_{j\max}$ for DC gate current
SWITCHING				
$(di_T/dt)_{crit}$	Critical rate of rise of on-state current non-repetitive (f=1 Hz)	A/ μ s	2000	$T_j = T_{j\max}$; $V_D = 0.67 \cdot V_{DRM}$; $I_{TM} = 2800$ A; Gate pulse: $I_G = 2$ A; $V_G = 20$ V; $t_{GP} = 50$ μ s; $di_G/dt = 2$ A/ μ s
THERMAL				
T_{stg}	Storage temperature	$^{\circ}$ C	-60...+50	
T_j	Operating junction temperature	$^{\circ}$ C	-60...+125	
MECHANICAL				
F	Mounting force	kN	24.0...28.0	
a	Acceleration	m/s ²	50	Device clamped

CHARACTERISTICS

Symbols and parameters		Units	Values	Conditions	
ON-STATE					
V_{TM}	Peak on-state voltage, max	V	2.35	$T_j = 25$ $^{\circ}$ C; $I_{TM} = 3140$ A	
$V_{T(TO)}$	On-state threshold voltage, max	V	1.397	$T_j = T_{j\max}$;	
r_T	On-state slope resistance, max	m Ω	0.313	$0.5 \pi I_{TAV} < I_T < 1.5 \pi I_{TAV}$	
I_H	Holding current, max	mA	500	$T_j = 25$ $^{\circ}$ C; $V_D = 12$ V; Gate open	
BLOCKING					
I_{DRM}, I_{RRM}	Repetitive peak off-state and Repetitive peak reverse currents, max	mA	150	$T_j = T_{j\max}$; $V_D = V_{DRM}$; $V_R = V_{RRM}$	
$(dv_D/dt)_{crit}$	Critical rate of rise of off-state voltage ¹⁾ , min	V/ μ s	200, 320, 500, 1000, 1600, 2000, 2500	$T_j = T_{j\max}$; $V_D = 0.67 \cdot V_{DRM}$; Gate open	
TRIGGERING					
V_{GT}	Gate trigger direct voltage, max	V	3.00 2.50 1.50	$T_j = T_{j\min}$ $T_j = 25$ $^{\circ}$ C $T_j = T_{j\max}$	$V_D = 12$ V; $I_D = 3$ A; Direct gate current
I_{GT}	Gate trigger direct current, max	mA	500 300 150	$T_j = T_{j\min}$ $T_j = 25$ $^{\circ}$ C $T_j = T_{j\max}$	
V_{GD}	Gate non-trigger direct voltage, min	V	0.40	$T_j = T_{j\max}$; $V_D = 0.67 \cdot V_{DRM}$;	
I_{GD}	Gate non-trigger direct current, min	mA	75.00	Direct gate current	
SWITCHING					
t_{gd}	Delay time, max	μ s	0.90	$T_j = 25$ $^{\circ}$ C; $V_D = 1000$ V; $I_{TM} = I_{TAV}$; $di/dt = 200$ A/ μ s;	
t_{gt}	Turn-on time ²⁾ , max	μ s	2.00, 2.50, 3.20, 4.00	Gate pulse: $I_G = 2$ A; $V_G = 20$ V; $t_{GP} = 50$ μ s; $di_G/dt = 2$ A/ μ s	
t_q	Turn-off time ³⁾ max	μ s	20.0, 25.0, 32.0, 40.0 25.0, 32.0, 40.0, 50.0	$dv_D/dt = 50$ V/ μ s; $dv_D/dt = 200$ V/ μ s;	$T_j = T_{j\max}$; $I_{TM} = I_{TAV}$; $di_R/dt = -10$ A/ μ s; $V_R = 100$ V; $V_D = 0.67 \cdot V_{DRM}$
Q_{rr}	Total recovered charge, max	μ C	450	$T_j = T_{j\max}$; $I_{TM} = 1000$ A;	
t_{rr}	Reverse recovery time, typ	μ s	6.3	$di_R/dt = -50$ A/ μ s;	
I_{rM}	Peak reverse recovery current, max	A	175	$V_R = 100$ V	

EVLYS LTD. - POWER SEMICONDUCTORS DEVICES - Wholesale and Retail.

THERMAL					
R_{thjc}	Thermal resistance, junction to case, max	°C/W	0.0210	Direct current	Double side cooled
R_{thjc-A}			0.0462		Anode side cooled
R_{thjc-K}			0.0378		Cathode side cooled
R_{thck}	Thermal resistance, case to heatsink, max	°C/W	0.0040	Direct current	
MECHANICAL					
w	Weight, max	g	510		
D_s	Surface creepage distance	mm (inch)	31.60 (1.244)		
D_a	Air strike distance	mm (inch)	16.50 (0.649)		

PART NUMBERING GUIDE								NOTES																																											
FDT	56	1000	22	7	5	4																																													
1	2	3	4	5	6	7																																													
1. FDT — Fast Inverter Disc Thyristor 2. Design version 3. Mean on-state current, A 4. Voltage code 5. Critical rate of rise of off-state voltage 6. Group of turn-off time ($dv_D/dt=50\text{ V}/\mu\text{s}$) 7. Group of turn-on time								1) Critical rate of rise of off-state voltage <table border="1" style="width: 100%; border-collapse: collapse;"> <thead> <tr> <th style="background-color: #cccccc;">Symbol of Group</th> <th style="background-color: #cccccc;">4</th> <th style="background-color: #cccccc;">5</th> <th style="background-color: #cccccc;">6</th> <th style="background-color: #cccccc;">7</th> <th style="background-color: #cccccc;">8</th> <th style="background-color: #cccccc;">8,5</th> <th style="background-color: #cccccc;">9</th> </tr> </thead> <tbody> <tr> <td>$(dv_D/dt)_{crit}, \text{ V}/\mu\text{s}$</td> <td>200</td> <td>320</td> <td>500</td> <td>1000</td> <td>1600</td> <td>2000</td> <td>2500</td> </tr> </tbody> </table> 2) Turn-on time <table border="1" style="width: 100%; border-collapse: collapse;"> <thead> <tr> <th style="background-color: #cccccc;">Symbol of group</th> <th style="background-color: #cccccc;">4</th> <th style="background-color: #cccccc;">3</th> <th style="background-color: #cccccc;">3</th> <th style="background-color: #cccccc;">2</th> </tr> </thead> <tbody> <tr> <td>$t_{gt}, \mu\text{s}$</td> <td>2.00</td> <td>2.50</td> <td>3.20</td> <td>4.00</td> </tr> </tbody> </table> 3) Turn-off time ($dv_D/dt=50\text{ V}/\mu\text{s}$) <table border="1" style="width: 100%; border-collapse: collapse;"> <thead> <tr> <th style="background-color: #cccccc;">Symbol of group</th> <th style="background-color: #cccccc;">6</th> <th style="background-color: #cccccc;">5</th> <th style="background-color: #cccccc;">4</th> <th style="background-color: #cccccc;">3</th> </tr> </thead> <tbody> <tr> <td>$t_q, \mu\text{s}$</td> <td>20.0</td> <td>25.0</td> <td>32.0</td> <td>40.0</td> </tr> </tbody> </table>								Symbol of Group	4	5	6	7	8	8,5	9	$(dv_D/dt)_{crit}, \text{ V}/\mu\text{s}$	200	320	500	1000	1600	2000	2500	Symbol of group	4	3	3	2	$t_{gt}, \mu\text{s}$	2.00	2.50	3.20	4.00	Symbol of group	6	5	4	3	$t_q, \mu\text{s}$	20.0	25.0	32.0	40.0
Symbol of Group	4	5	6	7	8	8,5	9																																												
$(dv_D/dt)_{crit}, \text{ V}/\mu\text{s}$	200	320	500	1000	1600	2000	2500																																												
Symbol of group	4	3	3	2																																															
$t_{gt}, \mu\text{s}$	2.00	2.50	3.20	4.00																																															
Symbol of group	6	5	4	3																																															
$t_q, \mu\text{s}$	20.0	25.0	32.0	40.0																																															

EVLYS LTD. - POWER SEMICONDUCTORS DEVICES - Wholesale and Retail.

OVERALL DIMENSIONS

Package type: T.D5

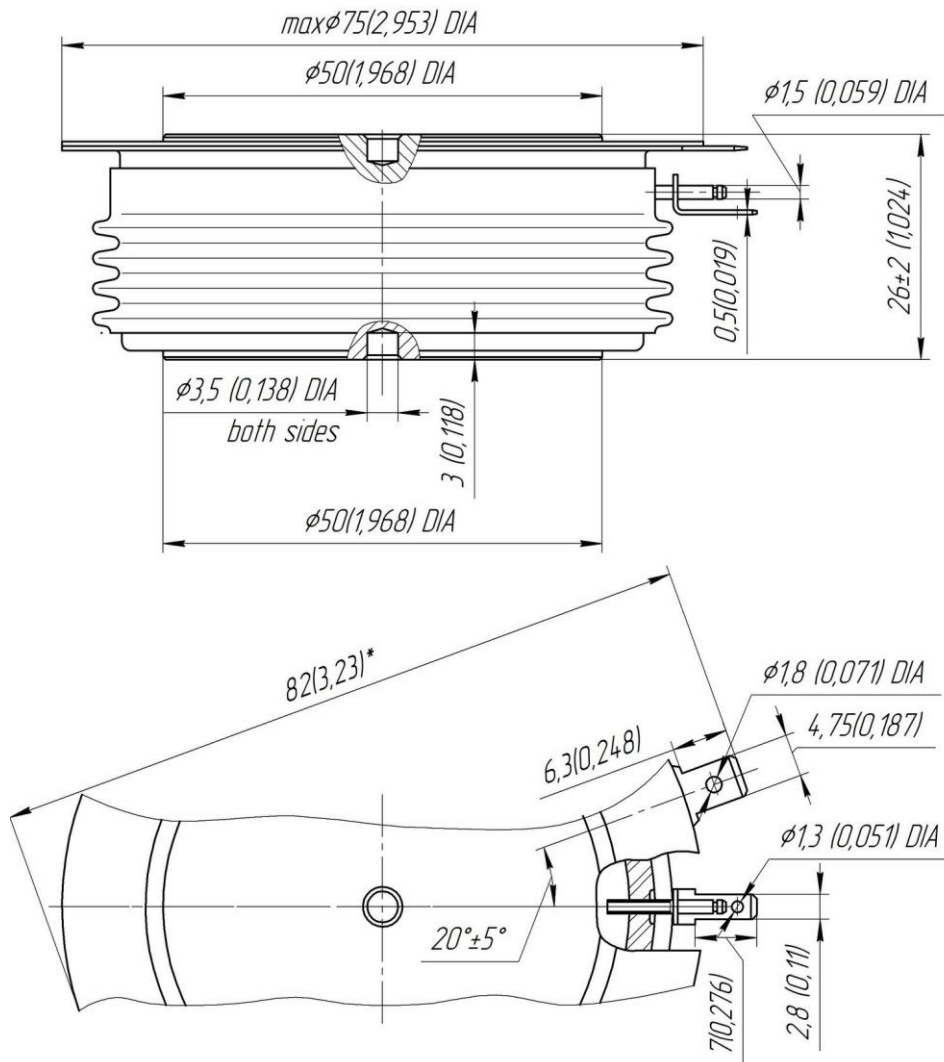

All dimensions in millimeters (inches)

EVLYS LTD. - POWER SEMICONDUCTORS DEVICES - Wholesale and Retail.