

# EVLYS LTD. - POWER SEMICONDUCTORS DEVICES - Wholesale and Retail.

## Fast Inverter Stud Thyristor Type **FST32-200-14**

Pressure contact / Low switching losses / Low reverse recovery charge  
High power cycling capability / Distributed amplified gate for high di<sub>r</sub>/dt

Mean on-state current		$I_{TAV}$		200 A	
Repetitive peak off-state voltage		$V_{DRM}$		1000...1400 V	
Repetitive peak reverse voltage		$V_{RRM}$			
Turn-off time		$t_q$		20.0, 25.0, 32.0, 40.0 $\mu$ s	
$V_{DRM}, V_{RRM}, V$	1000	1100	1200	1300	1400
Voltage code	10	11	12	13	14
$T_j, ^\circ C$	-60...+125				

### MAXIMUM ALLOWABLE RATINGS

Symbols and parameters		Units	Values	Test conditions	
<b>ON-STATE</b>					
$I_{TAV}$	Maximum allowable mean on-state current	A	200 247 365	$T_c=95^\circ C$ ; $T_c=85^\circ C$ ; $T_c=55^\circ C$ ; 180° half-sine wave; 50 Hz	
$I_{TRMS}$	RMS on-state current	A	314	$T_c=95^\circ C$ ; 180° half-sine wave; 50 Hz	
$I_{TSM}$	Surge on-state current	kA	6.5 7.5	$T_j=T_{j\max}$ $T_j=25^\circ C$	180° half-sine wave; $t_p=10$ ms; single pulse; $V_D=V_R=0$ V; Gate pulse: $I_G=I_{FGM}$ ; $V_G=20$ V; $t_{GP}=50$ $\mu$ s; $di_G/dt=1$ A/ $\mu$ s
			7.0 8.0	$T_j=T_{j\max}$ $T_j=25^\circ C$	180° half-sine wave; $t_p=8.3$ ms; single pulse; $V_D=V_R=0$ V; Gate pulse: $I_G=I_{FGM}$ ; $V_G=20$ V; $t_{GP}=50$ $\mu$ s; $di_G/dt=1$ A/ $\mu$ s
$I^2t$	Safety factor	$A^2s \cdot 10^3$	210 280	$T_j=T_{j\max}$ $T_j=25^\circ C$	180° half-sine wave; $t_p=10$ ms; single pulse; $V_D=V_R=0$ V; Gate pulse: $I_G=I_{FGM}$ ; $V_G=20$ V; $t_{GP}=50$ $\mu$ s; $di_G/dt=1$ A/ $\mu$ s
			200 260	$T_j=T_{j\max}$ $T_j=25^\circ C$	180° half-sine wave; $t_p=8.3$ ms; single pulse; $V_D=V_R=0$ V; Gate pulse: $I_G=I_{FGM}$ ; $V_G=20$ V; $t_{GP}=50$ $\mu$ s; $di_G/dt=1$ A/ $\mu$ s
<b>BLOCKING</b>					
$V_{DRM}, V_{RRM}$	Repetitive peak off-state and Repetitive peak reverse voltages	V	1000...1400	$T_{j\min} < T_j < T_{j\max}$ ; 180° half-sine wave; 50 Hz; Gate open	
$V_{DSM}, V_{RSM}$	Non-repetitive peak off-state and Non-repetitive peak reverse voltages	V	1100...1500	$T_{j\min} < T_j < T_{j\max}$ ; 180° half-sine wave; single pulse; Gate open	
$V_D, V_R$	Direct off-state and Direct reverse voltages	V	$0.6 \cdot V_{DRM}$ $0.6 \cdot V_{RSM}$	$T_j=T_{j\max}$ ; Gate open	

# EVLYS LTD. - POWER SEMICONDUCTORS DEVICES - Wholesale and Retail.

<b>TRIGGERING</b>				
$I_{FGM}$	Peak forward gate current	A	6	$T_j = T_{j\max}$
$V_{RGM}$	Peak reverse gate voltage	V	5	
$P_G$	Gate power dissipation	W	3	$T_j = T_{j\max}$ for DC gate current
<b>SWITCHING</b>				
$(di_T/dt)_{crit}$	Critical rate of rise of on-state current non-repetitive (f=1 Hz)	A/ $\mu$ s	1600	$T_j = T_{j\max}$ ; $V_D = 0.67 \cdot V_{DRM}$ ; $I_{TM} = 400$ A; Gate pulse: $I_G = 2$ A; $V_G = 20$ V; $t_{GP} = 50$ $\mu$ s; $di_G/dt = 2$ A/ $\mu$ s
<b>THERMAL</b>				
$T_{stg}$	Storage temperature	$^{\circ}$ C	-60...+50	
$T_j$	Operating junction temperature	$^{\circ}$ C	-60...+125	
<b>MECHANICAL</b>				
M	Tightening torque	Nm	25...35	
a	Acceleration	m/s <sup>2</sup>	100	

## CHARACTERISTICS

Symbols and parameters		Units	Values	Conditions	
<b>ON-STATE</b>					
$V_{TM}$	Peak on-state voltage, max	V	1.96	$T_j = 25$ $^{\circ}$ C; $I_{TM} = 628$ A	
$V_{T(TO)}$	On-state threshold voltage, max	V	1.158	$T_j = T_{j\max}$ ;	
$r_T$	On-state slope resistance, max	m $\Omega$	1.227	$0.5 \pi I_{TAV} < I_T < 1.5 \pi I_{TAV}$	
$I_H$	Holding current, max	mA	500	$T_j = 25$ $^{\circ}$ C; $V_D = 12$ V; Gate open	
<b>BLOCKING</b>					
$I_{DRM}, I_{RRM}$	Repetitive peak off-state and Repetitive peak reverse currents, max	mA	70	$T_j = T_{j\max}$ ; $V_D = V_{DRM}$ ; $V_R = V_{RRM}$	
$(dv_D/dt)_{crit}$	Critical rate of rise of off-state voltage <sup>1)</sup> , min	V/ $\mu$ s	200, 320, 500, 1000, 1600, 2000, 2500	$T_j = T_{j\max}$ ; $V_D = 0.67 \cdot V_{DRM}$ ; Gate open	
<b>TRIGGERING</b>					
$V_{GT}$	Gate trigger direct voltage, max	V	3.00 2.50 1.50	$T_j = T_{j\min}$ $T_j = 25$ $^{\circ}$ C $T_j = T_{j\max}$	$V_D = 12$ V; $I_D = 3$ A; Direct gate current
$I_{GT}$	Gate trigger direct current, max	mA	400 250 150	$T_j = T_{j\min}$ $T_j = 25$ $^{\circ}$ C $T_j = T_{j\max}$	
$V_{GD}$	Gate non-trigger direct voltage, min	V	0.45	$T_j = T_{j\max}$ ;	
$I_{GD}$	Gate non-trigger direct current, min	mA	40.00	$V_D = 0.67 \cdot V_{DRM}$ ; Direct gate current	
<b>SWITCHING</b>					
$t_{gd}$	Delay time, max	$\mu$ s	0.75	$T_j = 25$ $^{\circ}$ C; $V_D = 600$ V; $I_{TM} = I_{TAV}$ ; $di/dt = 200$ A/ $\mu$ s;	
$t_{gt}$	Turn-on time <sup>2)</sup> , max	$\mu$ s	1.60, 2.00, 2.50, 3.20	Gate pulse: $I_G = 2$ A; $V_G = 20$ V; $t_{GP} = 50$ $\mu$ s; $di_G/dt = 2$ A/ $\mu$ s	
$t_q$	Turn-off time <sup>3)</sup> , max	$\mu$ s	20.0, 25.0, 32.0, 40.0	$dv_D/dt = 50$ V/ $\mu$ s; $T_j = T_{j\max}$ ; $I_{TM} = I_{TAV}$ ; $di_R/dt = -10$ A/ $\mu$ s; $V_R = 100$ V; $V_D = 0.67 V_{DRM}$	
$Q_{rr}$	Recovered charge, max	$\mu$ C	150	$T_j = T_{j\max}$ ; $I_{TM} = I_{TAV}$ ;	
$t_{rr}$	Reverse recovery time, max	$\mu$ s	3.2	$di_R/dt = -50$ A/ $\mu$ s;	
$I_{rr}$	Reverse recovery current, max	A	94	$V_R = 100$ V	

# EVLYS LTD. - POWER SEMICONDUCTORS DEVICES - Wholesale and Retail.

<b>THERMAL</b>				
$R_{thjc}$	Thermal resistance, junction to case, max	$^{\circ}C/W$	0.085	Direct current
<b>MECHANICAL</b>				
m	Weight, max	g	440	
$D_s$	Surface creepage distance	mm (inch)	12.4 (4.882)	
$D_a$	Air strike distance	mm (inch)	12.4 (4.882)	

<b>PART NUMBERING GUIDE</b>								<b>NOTES</b>																							
FST	32	200	14	7	5	4		1) Critical rate of rise of off-state voltage																							
1	2	3	4	5	6	7		<table border="1" style="width: 100%; border-collapse: collapse;"> <thead> <tr> <th style="background-color: #cccccc;">Symbol of Group</th> <th style="background-color: #cccccc;">4</th> <th style="background-color: #cccccc;">5</th> <th style="background-color: #cccccc;">6</th> <th style="background-color: #cccccc;">7</th> <th style="background-color: #cccccc;">8</th> <th style="background-color: #cccccc;">8,5</th> <th style="background-color: #cccccc;">9</th> </tr> </thead> <tbody> <tr> <td><math>(dv_D/dt)_{crit}, V/\mu s</math></td> <td>200</td> <td>320</td> <td>500</td> <td>1000</td> <td>1600</td> <td>2000</td> <td>2500</td> </tr> </tbody> </table>								Symbol of Group	4	5	6	7	8	8,5	9	$(dv_D/dt)_{crit}, V/\mu s$	200	320	500	1000	1600	2000	2500
Symbol of Group	4	5	6	7	8	8,5	9																								
$(dv_D/dt)_{crit}, V/\mu s$	200	320	500	1000	1600	2000	2500																								
1. FST — Fast Inverter Stud Thyristor								2) Turn-on time																							
2. Design version								<table border="1" style="width: 100%; border-collapse: collapse;"> <thead> <tr> <th style="background-color: #cccccc;">Symbol of group</th> <th style="background-color: #cccccc;">6</th> <th style="background-color: #cccccc;">5</th> <th style="background-color: #cccccc;">4</th> <th style="background-color: #cccccc;">3</th> </tr> </thead> <tbody> <tr> <td><math>t_{gt}, \mu s</math></td> <td>1.60</td> <td>2.00</td> <td>2.50</td> <td>3.20</td> </tr> </tbody> </table>								Symbol of group	6	5	4	3	$t_{gt}, \mu s$	1.60	2.00	2.50	3.20						
Symbol of group	6	5	4	3																											
$t_{gt}, \mu s$	1.60	2.00	2.50	3.20																											
3. Mean on-state current, A								3) Turn-off time ( $dv_D/dt=50 V/\mu s$ )																							
4. Voltage code								<table border="1" style="width: 100%; border-collapse: collapse;"> <thead> <tr> <th style="background-color: #cccccc;">Symbol of group</th> <th style="background-color: #cccccc;">6</th> <th style="background-color: #cccccc;">5</th> <th style="background-color: #cccccc;">4</th> <th style="background-color: #cccccc;">3</th> </tr> </thead> <tbody> <tr> <td><math>t_{qt}, \mu s</math></td> <td>20.0</td> <td>25.0</td> <td>32.0</td> <td>40.0</td> </tr> </tbody> </table>								Symbol of group	6	5	4	3	$t_{qt}, \mu s$	20.0	25.0	32.0	40.0						
Symbol of group	6	5	4	3																											
$t_{qt}, \mu s$	20.0	25.0	32.0	40.0																											
5. Critical rate of rise of off-state voltage																															
6. Group of turn-off time ( $dv_D/dt=50 V/\mu s$ )																															
7. Group of turn-on time																															

# EVLYS LTD. - POWER SEMICONDUCTORS DEVICES - Wholesale and Retail.

## OVERALL DIMENSIONS

Package type: **T.SB2**

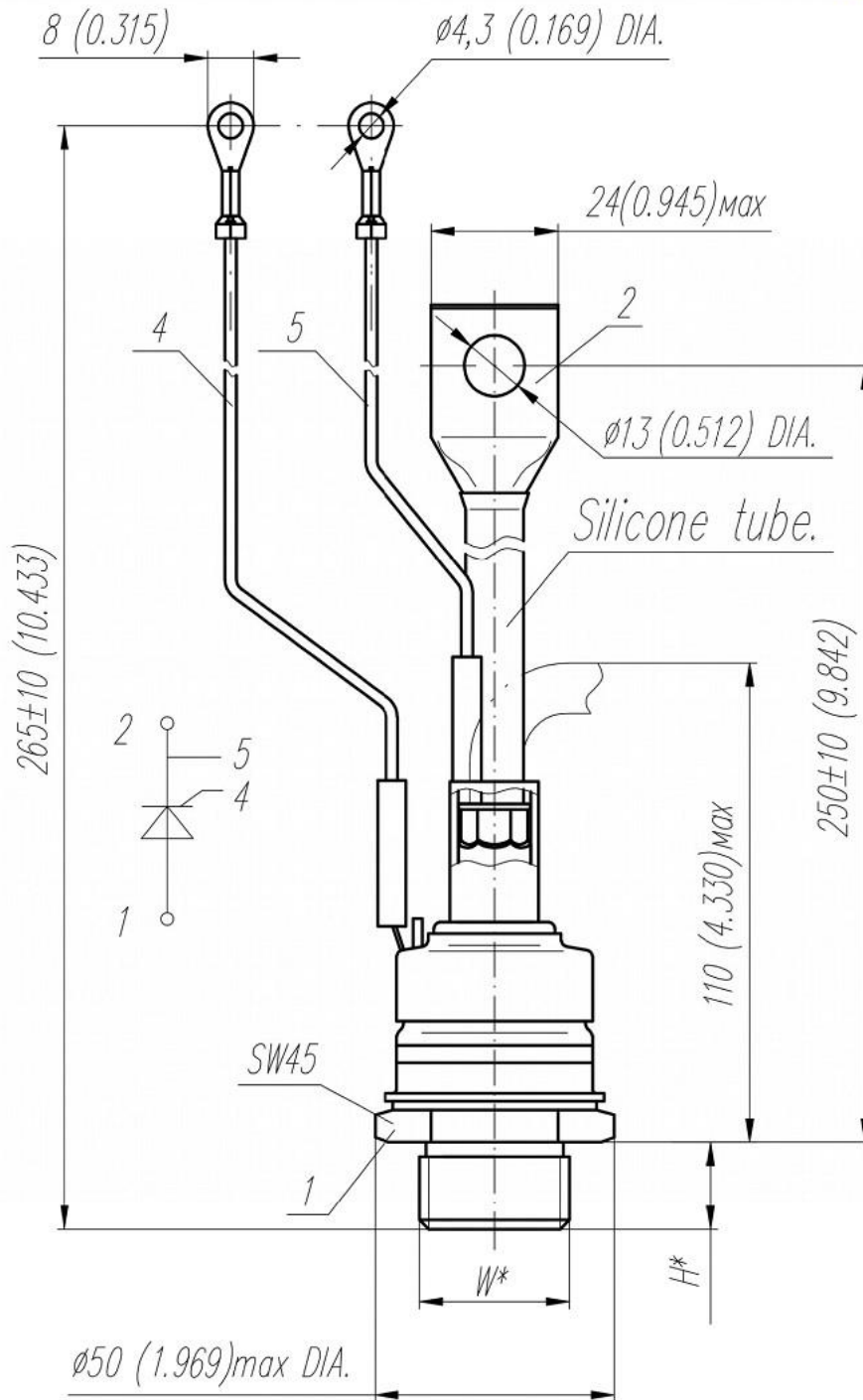

Type of screw	W	H
Metric Screw Type C	M24x1,5 – 8g	19
		15

Polarity	Example of code designation	Reference designation	Colors		
			Anode	Cathode	Gate
Anode to stud	FST32_37		-	Red tube	White

All dimensions in millimeters (inches)